

# User Manual

## Model No.:ML-L100

### Portable Rechargeable LED Work Light



Thanks for choosing the ML-L100P ortable Rechargeable LED Work Light.  
Please read this manual carefully before use and retain it for later use(rs)!



# Contents

|          |   |          |
|----------|---|----------|
| <b>1</b> | <b>WORK LIGHT APPLICATION AND FEATURES .....</b>                  | <b>3</b> |
| 1.1      | WORK LIGHT APPLICATION.....                                       | 3        |
| 1.2      | WORK LIGHT FEATURES.....  | 3        |
| <b>2</b> | <b>SPECIFICATION DETAILS .....</b>                                | <b>4</b> |
| <b>3</b> | <b>APPEARANCE AND PARTS LIST .....</b>                            | <b>5</b> |
| <b>4</b> | <b>DIRECTION FOR USE .....</b>                                    | <b>6</b> |
| 4.1      | HOW TO DEPLOY THE WORK LIGHT FOR LIGHTING .....                   | 6        |
| 4.2      | 12-24V DC CAR CHARGER FUNCTION OF DIRECT USE .....                | 7        |
| 4.3      | HOW TO CLOSE THE WORK LIGHT FOR PORTABLE LIGHTING AND CARRY ..... | 7        |
| <b>5</b> | <b>SWITCH FUNCTION.....</b>                                       | <b>8</b> |
| <b>6</b> | <b>BATTERY REPLACEMENT AND CHARGING FUNCTION .....</b>            | <b>8</b> |
| 6.1      | BATTERY REPLACEMENT.....  | 8        |
| 6.2      | CHARGING FUNCTION .....   | 9        |
| 6.3      | CHARGING STATION WITH INTELLECTIVE LED INDICATIONS .....          | 9        |
| <b>7</b> | <b>NOTICE AND CAUTIONS.....</b>                                   | <b>9</b> |
| 7.1      | LITHIUM ION REMOVABLE & RECHARGEABLE BATTERY PACK.....            | 9        |
| 7.2      | WORK LIGHT CARE .....   | 10       |

# Portable Rechargeable LED Work Light User Manual

## 1 Work light application and features

### 1.1 Work light application

Portable rechargeable LED work light uses advanced Cree® LED in the world. It has lots of advantage, such as high brightness, low energy consumption, good radiating of pure aluminum, long life and so on. The work light incorporates both practicability and beauty as a whole. As a work lighting, it can be an ideal substitute for traditional work light. It is green energy-saving and environmental protection. There are no harmful substances, no glare, no stroboscopic, and low current without hazard of electric shock.

The work light that can be used portably both indoors and outdoors are dustproof, rainproof, windproof and drop-proof. For example:

- ◆ **Workshop and machine maintenance lighting**
- ◆ **Home life and emergency lighting**
- ◆ **Project and construction of lighting**
- ◆ **Camping and fishing lighting**
- ◆ **Auto and ship repair lighting**
- ◆ **Accident & emergency and rescue & disaster lighting**
- ◆ **Other places in where it need lighting and application**

### 1.2 Work light features

- ◆ Utility Model Patent: 201320543303.9
- ◆ Appearance Design Patent: 201330415948.X
- ◆ Housing of tough PA+GF plastic materials
- ◆ Sturdy collapsible tripod: easily deployable and steady support legs of durable ABS plastic materials (Different color available)
- ◆ Main body of high purity anodized aluminum coated with epoxy powder
- ◆ Swiveling head with 2 pcs Cree® XMLBWT-T6 super bright LED (5W per pc, 50000 hours); beam spread: 60°
- ◆ Battery type: 7.4V 4400mAh (32.56Wh, 500 cycles), Lithium ion removable & rechargeable battery pack
- ◆ Connected by 3m (10ft) heavy-gauge coil cord inside
- ◆ Telescopic aluminum mast up to height 1.8m (6ft) by fully adjustable height control
- ◆ To charge by fast AC home charger with different plug types, overcharge protection  
Input: 100-240V ~ 50/60Hz, Output: 12V 3A
- ◆ Charging station with intellectual LED indications:
  - ◆ Including a universal 12-24V DC charger with heavy-gauge 3m (10ft) coil cord and 8 A fuse tube, which can supply the power directly from vehicle to light. It can be also used to charge the battery pack fast on charging station (included)
  - ◆ Including a 12-24V rainproof DC jack with rubber cap of which always covered up probably. (Please cover it up after using)
  - ◆ The High/Low/S.O.S/off rainproof switch includes an illuminated battery status with intellectual LED indications
- ◆ Rainproof design. Indoor & Outdoor Use. Ingress protection: IP53; 3 circular holes on the feet for pegging if it is windy or on uneven ground

- ◆ Easy carry shoulder belt for portable use(included)
- ◆ Canvas storage bag(included)
- ◆ USB converter for charging cell phone(optional,**not included** in the price.Cost:TBD)

Converting the input jack to be output 5V 0.5A on the battery pack

- ◆ LED rubber warning light(optional,**not included** in the price.Cost:TBD).Easy and fast to fix on and remove from telescopic aluminum mast.Easy switch with 4 settings: full brightness,fast flashing alert,slow flashing alert,off

## 2 Specification details

|   |   |
|---|---|
| Name  | Portable Rechargeable LED Work Light  |
| Model No.   | ML-L100   |
| LED Quantity & Brand & Model No.                            | 2 pcs Cree® XMLBWT-T6 LED   |
| LED Electricity Consumption and Life                        | 5W per pc,total 10W,50000 hours   |
| Color Temperature   | 6000-7500 K   |
| Switch Function   | 4 Settings: High/Low/S.O.S/Off  |
| LED Light Output  | 1200 Lumens(high),600 Lumens(low)   |
| Max Beam Distance   | Spot and flood reflector is alternative.Spot:235M;Flood:85M   |
| Beam Spread   | 60 °  |
| Battery Type & Capacity & Life                              | Lithium ion,7.4V 4400mAh(32.56Wh),500 cycles  |
| Constant Run Time   | 3~3.5 Hours(high),6~7 hours(low)  |
| Charging time(Alternative Configurations for Fast Charging) | About 2.5 hour  |
| Light Size  | About φ120X740mm(Closed);φ780X1800mm(Deployable);   |
| Telescopic Mast   | Aluminum,3 pcs  |
| Length Closed   | 740 mm (2.43')  |
| Mast Height Extended  | About 1.8 m (6')  |
| The Rotated Angle of Light Head                             | 120°  |
| Weight (Battery Pack & Shoulder Belt Included)              | 3.2 kgs (7.05 lbs)  |
| Light Color   | Black,Yellow and Red(Different color available)   |
| Light Materials   | PA6+GF30;ABS;PC;Aluminum;Rubber and Copper  |
| Use Condition (Ingress Protection) and Drop Height          | Indoor & Outdoor Use(Rainproof,IP53),Drop Height :1m  |
| Fast AC Home Adapter  | With safety certificate of CE,PSE,UL,GS,VDE,SAA,KC,CCC,etc.;<br>Input:100-240V ~ 50/60Hz,Output:12V 3A<br>DC cord: 20 AWG,1.2 m;DC small plug: 90° ,5.5*2.1mm |
| AC Electric cord and AC Plug                                | With safety certificate of CE,PSE,UL,GS,VDE,SAA,KC,CCC,etc.;<br>AC Electric Cord:2 X 0.75mm <sup>2</sup> ,1.2 m;Plug:7A 125V                                  |
| 12-24V DC Charger   | 3m(10ft) coil cord and Replaceable 8 A fuse tube,<br>DC small plug: 90° ,5.5*2.1mm  |
| 7.4V Li-ion Charging Station                                | Input:DC 12 – 24V 3A 25.5W,Output:DC 8.5V 3A  |
| Shoulder Belt Size  | Width 37mm X Length1150mm   |
| Other   | Canvas storage bag; Charging station bag  |

### 3 Appearance and parts list

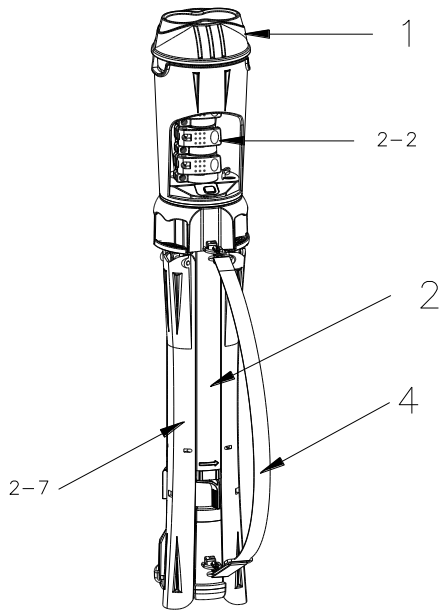

- ◆ LED light head.....(1)
- ◆ Upper and lower rotating part.....(1-1)
- ◆ Housing.....(1-2)
- ◆ Main body..... (2)
- ◆ Telescopic mast.....(2-1)
- ◆ Telescopic mast lock catch.....(2-2)
- ◆ Control system panel.....(2-3)
- ◆ Support collar.....(2-4)
- ◆ Tripod switch.....(2-5)
- ◆ Battery chamber.....(2-6)
- ◆ Tripod.....(2-7)
- ◆ Battery pack.....(3)
- ◆ Shoulder belt.....(4)
- ◆ Charging station.....(5)
- ◆ Fast AC home adapter.....(6)
- ◆ 12-24V DC car charger.....(7)
- ◆ Canvas storage bag.....(8)
- ◆ Charging station bag.....(8-1)

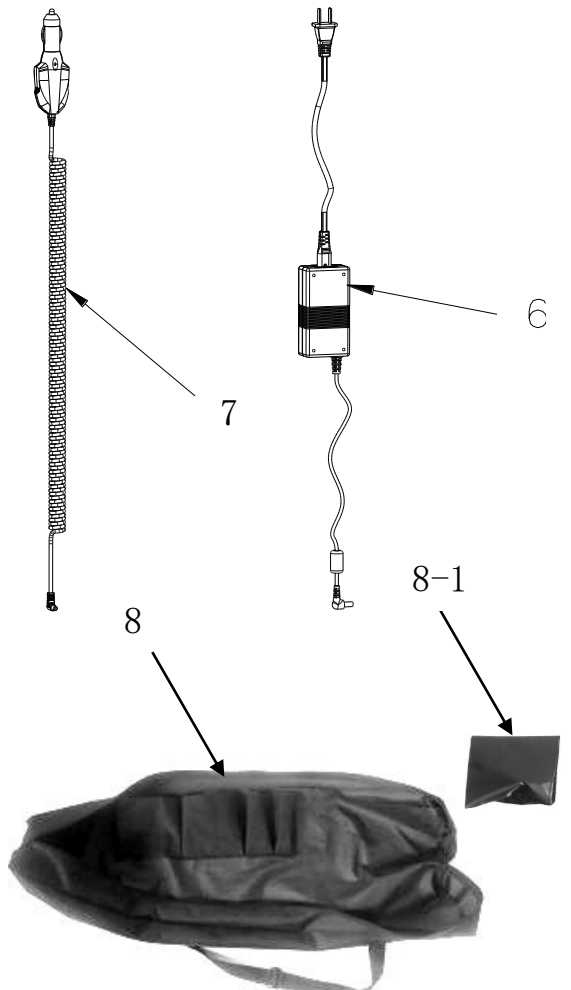
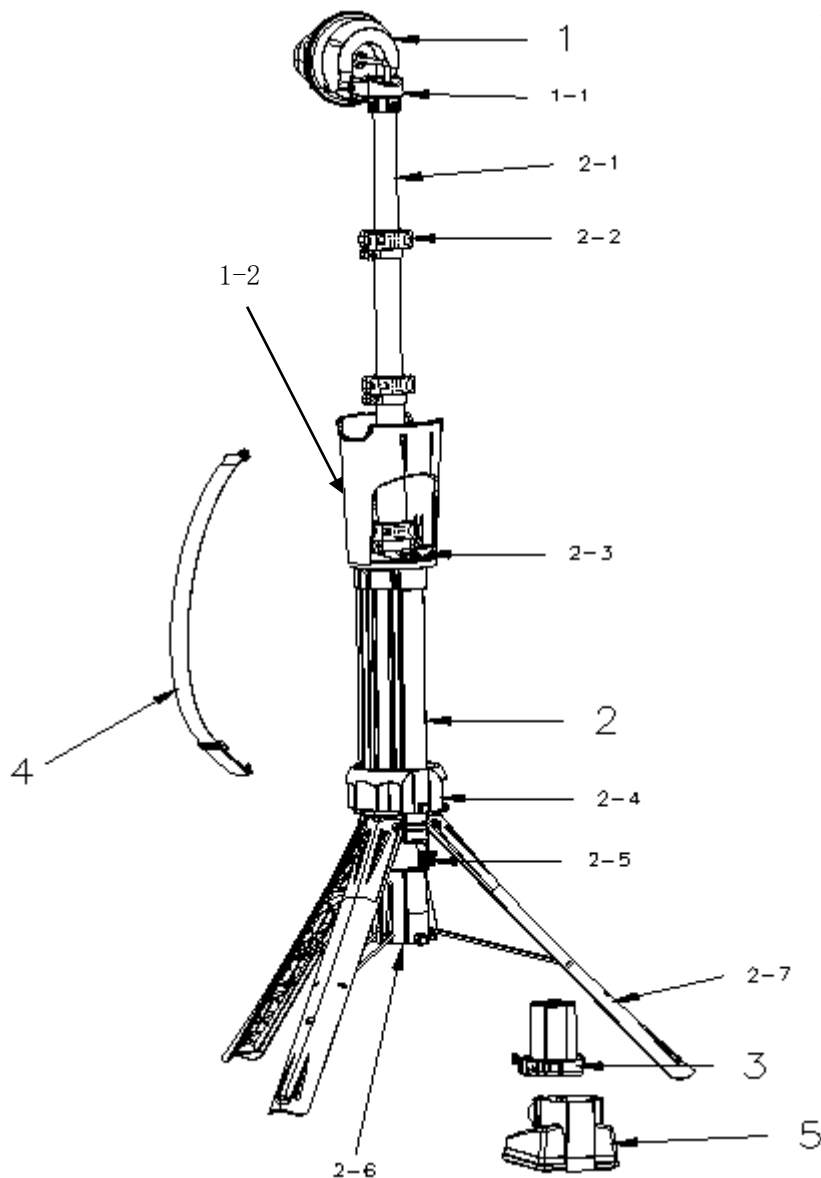

## 4 Direction for use

※**Caution:**Please ensure to keep fingers clear of moving parts at all times.Failure to comply could result in injury!

### 4.1 How to deploy the work light for lighting

①Please insert battery pack(3) into the battery chamber(2-6) first at the bottom of work light.

※**Caution:**Please ensure to align the two yellow ◀ patterns on battery pack(3) with the two yellow latches outside the battery chamber(2-6).



②Rotate tripod switch(2-5) at the bottom outside of main body(2).Tripod(2-7) will spring outwards automatically.

③Move support collar(2-4) towards tripod switch(2-5) that could be positioned,and simultaneously,tripod(2-7) supports the work light steadily on the ground.

④Open bottom telescopic mast lock catch(2-2) outwards, and then,take LED light head(1) out from the gap on both sides of housing(1-2). At last,lock telescopic mast lock catch(2-2) as required height of use.



⑤Similarly,open other telescopic mast lock catches(2-2) in turn,draw out telescopic mast(2-1) upwards so as to raise the LED light head(1) up to required height of use.,then lock telescopic mast lock catches(2-2)

⑥LED light head(1)could be rotated © to the required direction of lighting by the upper and lower rotating part(1-1) at the bottom.



## 4.2 12-24V DC car charger function of direct use

An universal 12-24V DC car charger(7) with heavy-gauge 3m(10ft) coil cord,which can supply the power directly from vehicle for the light.It can be also used to charge the battery pack fast on charging station(Please find more details in 6.2 of charging function description).

※**Caution:**It will stop using the power of battery pack (3) automatically when DC small plug are plugged in 12-24V DC jack in the middle of light. If you want to use the power of battery pack (3),please ensure to unplug the DC small plug.Please ensure to cover up DC jack with the rainproof cap after using.



## 4.3 How to close the work light for portable lighting and carry

※**Caution:**Please ensure to keep fingers clear of moving parts at all times.Failure to comply could result in injury.

①Rotating LED light head(1) is facing upwards,then close telescopic mast(2-1) from the bottom telescopic mast lock catch(2-2) to the top in turn,otherwise it does not go all the way down.

②Pull support collar(2-4) towards housing(1-2) so as to close tripod(2-7) towards main body(2).

③Press each leg of tripod(2-7) to latch inwards tripod switch(2-5), and simultaneously,retract LED light head(1) into housing(1-2), At last,lock all of telescopic mast lock catches(2-2).

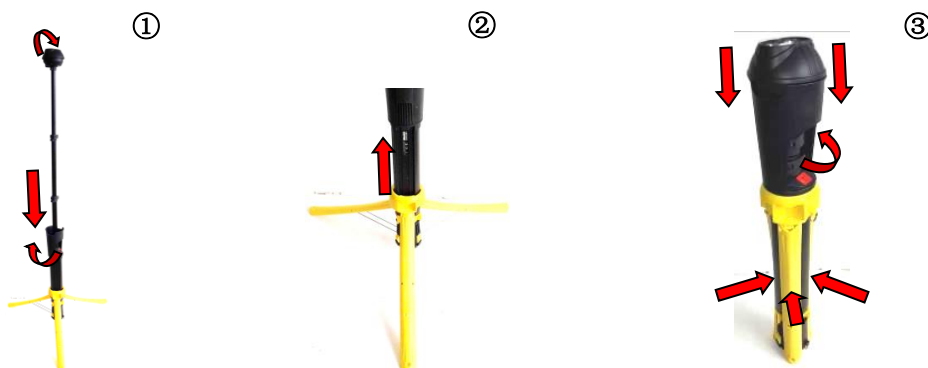

④Equipped with high quality shoulder belt(4) with sponge pad for portable use and carry,Its two metal hooks could be fastened with the buckles near to the housing(2).

⑤ LED light head(1) could light towards the front and bend to the ground.Easier to touch switch above control system panel(2-3).

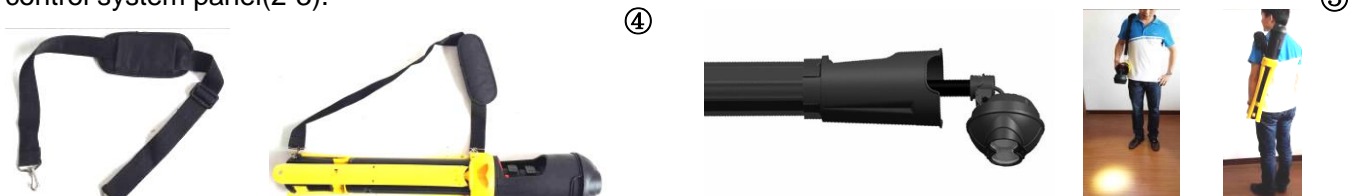

⑥Including high quality canvas storage bag(8) packed in all parts for easy carry.

※**Caution:**Put the charging station(5) into charging station bag(8-1) in order to avoid any scratches in the portable carry.



## 5 Switch function

Control system panel(2-3) are designed at the middle of main body, more humanized design,easier to touch and better for rainproof.

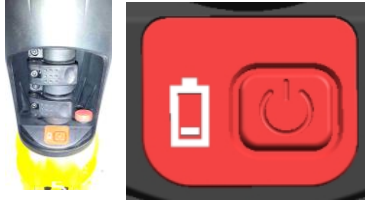
| Pictures  | Illuminated battery status with intellectual LED indications                             |
|---|--|
|   <p>4 Settings: High/Low/S.O.S/Off</p> | Solid Green = Good status  |
|   | Solid Orange = Suggest charging  |
|   | Red Flashing = Stop using or the light go out automatically as over-discharge protection |
|   | Off=Fault for LED indications of battery status  |

## 6 Battery replacement and charging function

### 6.1 Battery replacement

① Remove the battery pack(3) from base of work light by pressing the two yellow latches on the both sides of battery chamber(2-6) simultaneously and pulling it out.

①

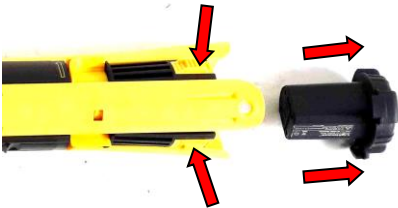

② Take battery pack(3) into charging station(5),

※**Caution:**Please ensure to align the two yellow patterns on battery pack(3) with the two yellow latches outside the charging station(5).

②



③ After charging completed,remove the battery pack(3) by pressing the two yellow latches on the both sides of charging station(5) simultaneously and pulling it out.

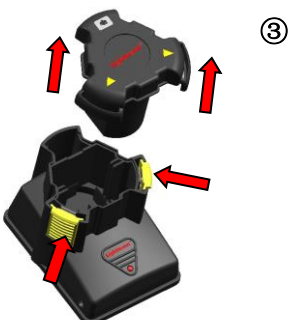



## 6.2 Charging function

Charging station(5) could be connected with fast AC home adapter(6) and 12-24V DC car charger(7) to charge battery pack(3) at different condition. Always remove battery pack (3) from charger once it is fully charged.

※**Caution:Charging time is about 2.5 hours**

①Fast AC home adapter(6) with safety certificate of CE,PSE,UL,GS,VDE,SAA,KC,CCC,etc.;;  
Input:100-240V ~ 50/60Hz,Output:12V 3A.





※**Caution:**Do not use any other non-standard power adapters or directly supply AC power for charging station(5) & work light.



②An universal 12-24V DC car charger(7) with heavy-gauge 3m(10ft) coil cord,which can supply the power directly from vehicle for the light.It can be also used to charge the battery pack fast on charging station.



## 6.3 Charging station with intellectual LED indications

| Pictures  | Charging station with intellectual LED indications |
|---|--|
|  | Solid Green = Power plugged in                     |
|  | Solid Red = Charging rapidly                       |
|  | Solid Green = Charging completed                   |
|  | Red/Green Flashing = Fault                         |

## 7 Notice and cautions

To ensure maximum product life please observe the following points.

### 7.1 Lithium ion removable & rechargeable battery pack

- ※Lithium Ion batteries can explode, leak or cause burns if not handled properly.
- ※Only use approved batteries on the product.
- ※Do not open batteries.
- ※Do not dispose of in fire.
- ※Do not heat above 140°F/60°C.
- ※Do not expose batteries to water or excessive humidity.
- ※Insert batteries correctly with regard to polarity (+ and -) marked on the battery and equipment

※Always dispose of all batteries properly at an approved battery recycling center.

## 7.2 Work light care

- ※Please ensure to keep fingers clear of moving parts at all times.Failure to comply could result in injury.
- ※Keep moving parts free of foreign objects.
- ※Do not stand on product.
- ※Avoid use on extreme gradients.
- ※The supply power of fast AC home adapter(6) are 100-240V.Electric Shock Risk. It should only be used under adult supervision.
- ※The fast AC home adapter(6) should be inserted into the 100-240V standard socket.
- ※The 12-24V DC car charger(7) should be inserted into the 12-24V standard socket.
- ※If there are any abnormal condition during the use of light, it should stop being used,unplugged the power,take out of battery pack and checked.
- ※It is rainproof but not waterproof. Do not immerse it in the water.
- ※It is not a toy and should be kept out of the reach of children.
- ※Regularly switching the light on and off reduces its life time considerably.
- ※Do not look directly into the beam.
- ※Attempt to disassemble the product can damage it and void your warranty.
- ※It should be ensured that its power are cut off when replacement,overhaul and cleaning-up.
- ※Do not short-circuit it.
- ※Do not use it if it is damaged.
- ※Keep the light clean and dry.

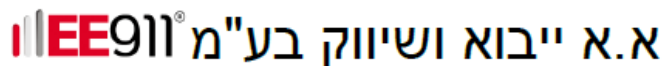
 א.א. ייבוא ושיווק בע"מ 909

מערכות תאורה הבהוב וכריזה

כתובת: רח' קשת 154 ישוב קידר מיקוד 90612 טל: 02-5906222 פקס: 057-9556666